

tekmar® Submittal

Snow Melting Control 654



654_C

05/13

Snow Melting Replaces: New

Job _____ Designer _____ Contact _____

The Snow Melting Control 654 is designed to operate electric or hydronic equipment to melt snow or ice from any surface including driveways, walkways, patios, business entrances, parking ramps, loading docks, hospital entrances, helipads or car wash bays. The surface temperature for snow melting is controlled automatically to reduce operating energy costs. The 654 has an automatic start and stop function when used with the Snow/Ice Sensor 090 or 094. Automatic start with a timed stop is available when used with the Snow Sensor 095. The 654 can operate a dedicated hydronic boiler or a mixing device. Isolation relays are required to operate line voltage pumps. Electric systems require a separate GFCI and electrical relay contactor.

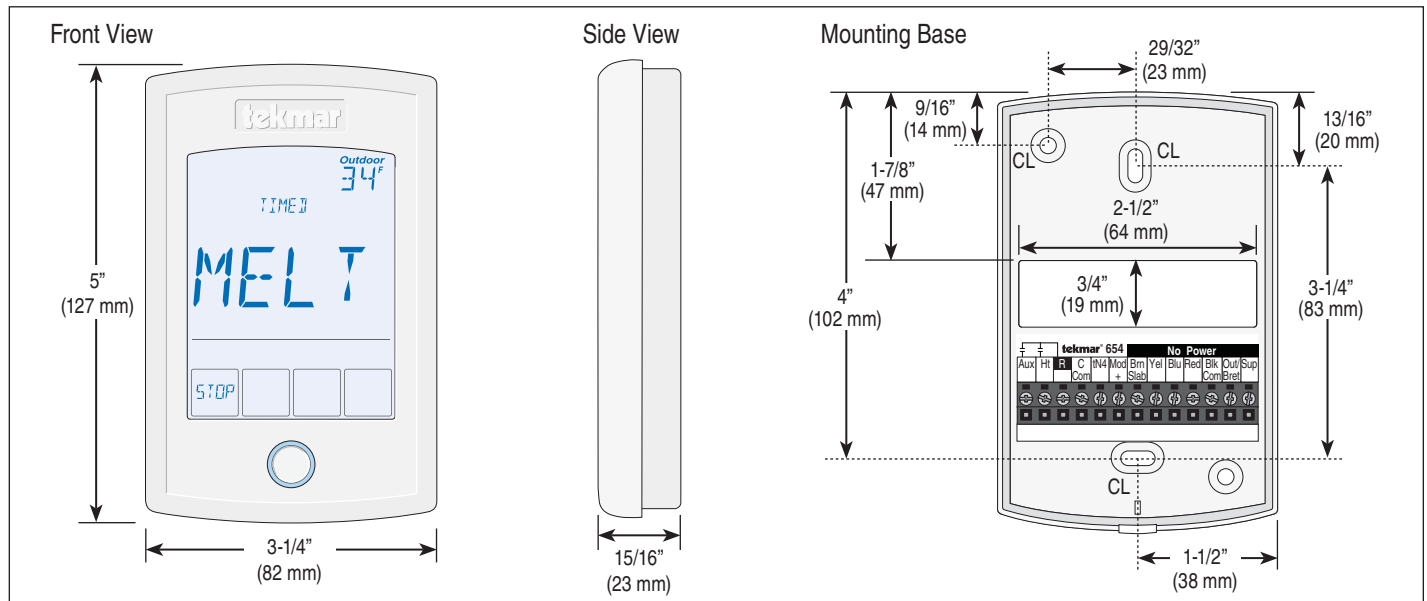

Specifications

Snow Melting Control 654 tekmarNet® Electric or Hydronic Boiler / Mixing	
Literature	654_A, 654_C, 654_D, 654_Q, 654_U
Control	Microprocessor control. This is not a safety (limit) control
Packaged weight	1.3 lb. (590 g)
Dimensions	5" H x 3-1/4" W x 15/16" D (127 x 82 x 23 mm)
Enclosure	White PVC plastic, NEMA type 1
Ambient conditions	-4 to 122°F (-20 to 50°C), < 90% RH non-condensing, outdoor use permitted when installed inside a NEMA 3 enclosure
Power supply	24 V (ac) ±10%, 60 Hz, Class 2, 16 VA standby, 100 VA fully loaded
Relay capacity	24 V (ac) 2 A, 3.6 A combined
Modulating output	0-10 V (dc), 500 Ω minimum load impedance, 4-20 mA 1 kΩ max load impedance
Sensors	NTC thermistor, 10 kΩ @ 77°F (25°C ±0.2°C) β=3892
-Included	Outdoor Sensor 070, Universal Sensor 082
-Optional	tekmar type #: 071, 072, 073, 082, 090, 091, 094, 095
Warranty	Limited 3 Year (See 654_D for full warranty)

Features

- Automatic Snow / Ice Detection
- Supports Both Inslab & Retrofit Aerial Sensors
- Manual Start With Timer
- Programmable Schedule
- tekmarNet® Communication Compatible
- Warm Weather Shut Down
- Cold Weather Cut Out
- Idling
- Snow Melt Zoning With Priority
- Tandem Snow / Ice Detection
- Slab Protection
- Storm
- EconoMelt
- Manual Override
- Snow Melt Zone Tracking
- Scenes
- Away Key
- Exercising
- Alert Output

SPECIAL REQUIREMENTS

Requires a Snow / Ice Sensor 090 or 094, or a Snow Sensor 095 for automatic start operation. A Slab Sensor 072 or 073 is recommended when a 090 or 094 is not installed.

Sample Application Drawing

Below is a sample application drawing for this product. This application may include other tekmar products that are required for installation. More sample applications can be found at www.tekmarControls.com.

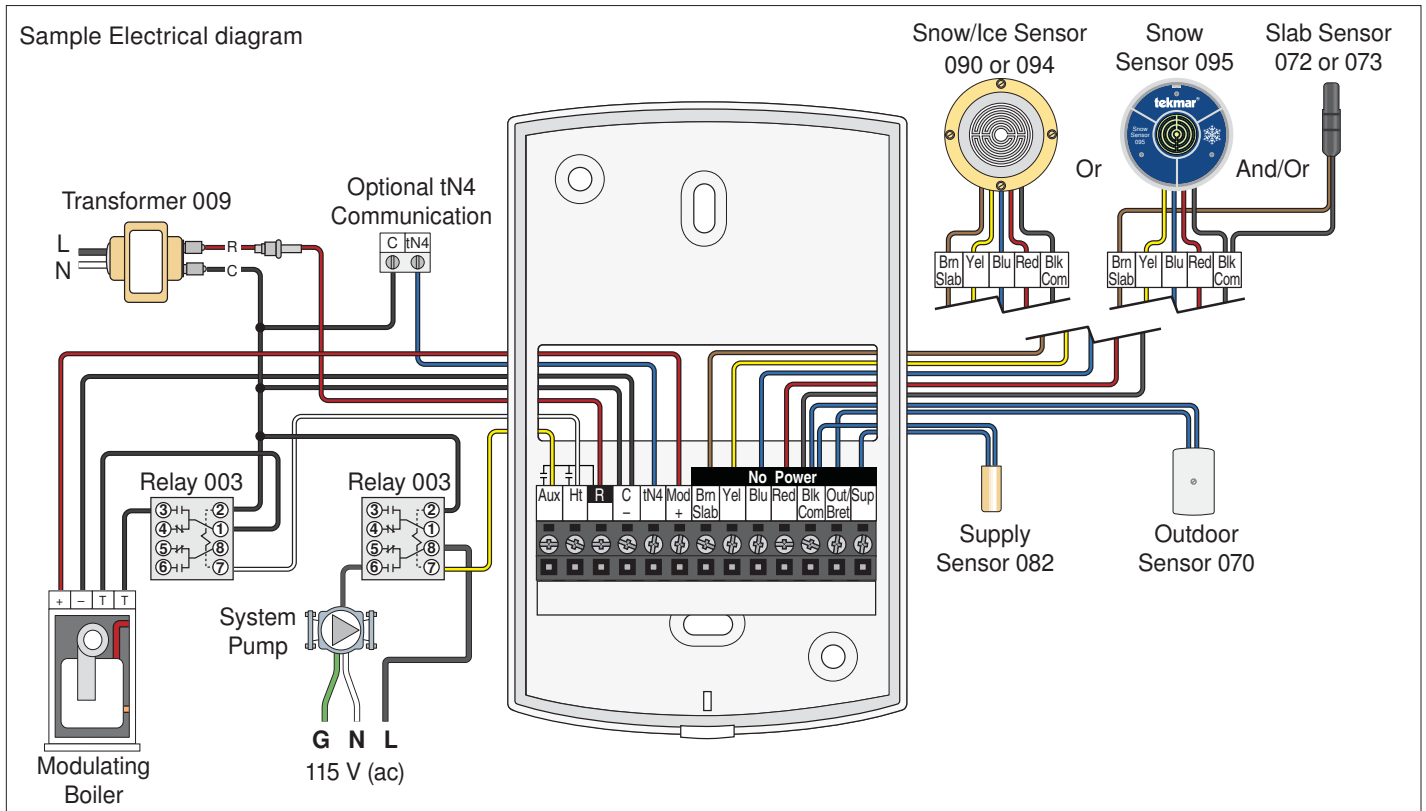
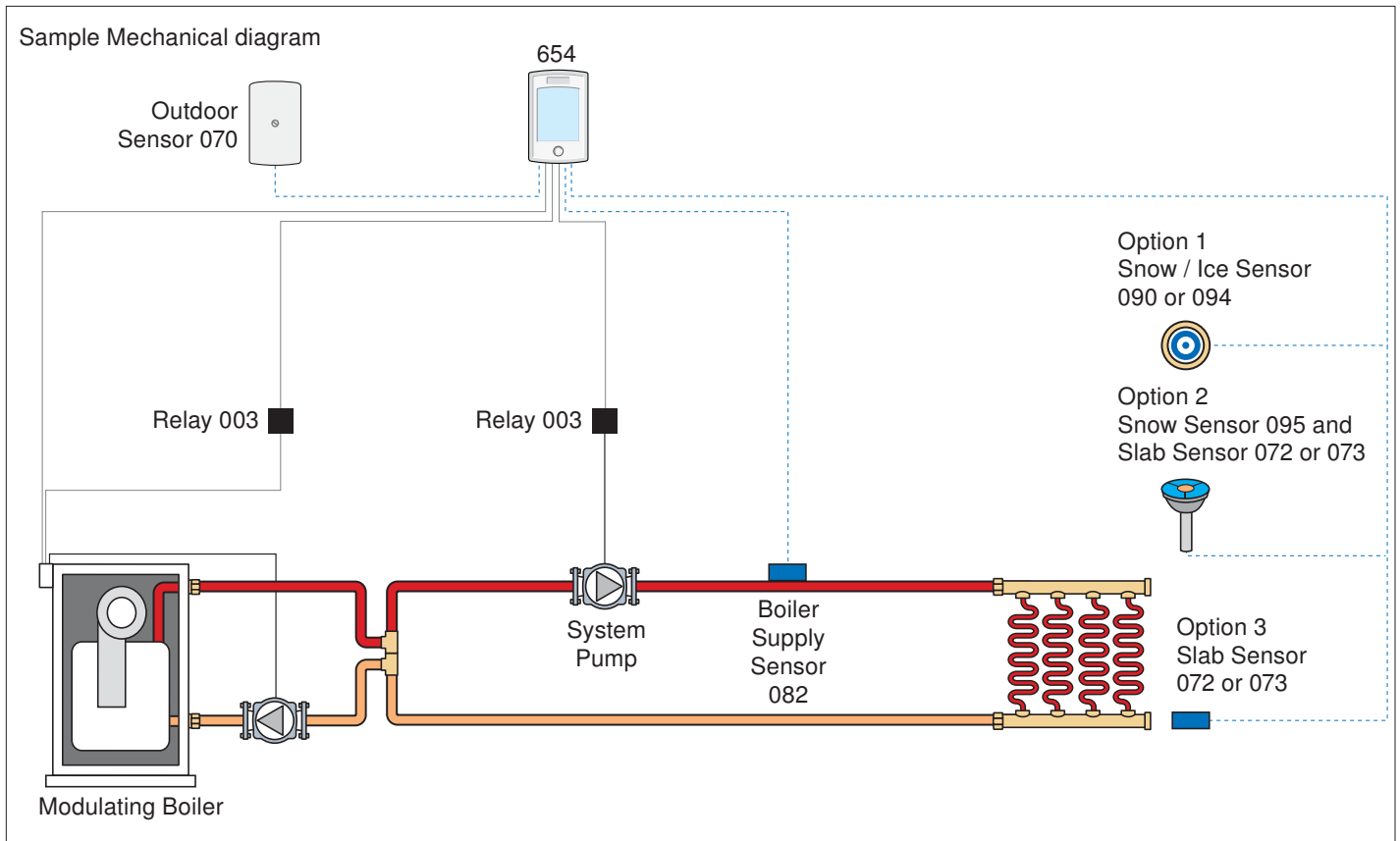

tekmar Control Systems Ltd., A Watts Water Technologies Company. Head Office: 5100 Silver Star Road, Vernon, B.C. Canada V1B 3K4, 250-545-7749, Fax. 250-545-0650 Web Site: www.tekmarControls.com

