

tekmar® Submittal

Boiler Control 260

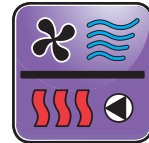

C 260

01/11

HVAC Systems Replaces: New

Job _____ Designer _____ Contact _____

The Boiler Control 260 is designed to operate a single boiler using outdoor reset. It can be used in applications ranging from baseboard or mixed radiant heating systems, to combination space heating and domestic hot water heating installations. This control regulates a single heating water temperature through outdoor reset and/or Domestic Hot Water control. It is capable of controlling a single on/off boiler and can receive both space heating and/or DHW heat demands.

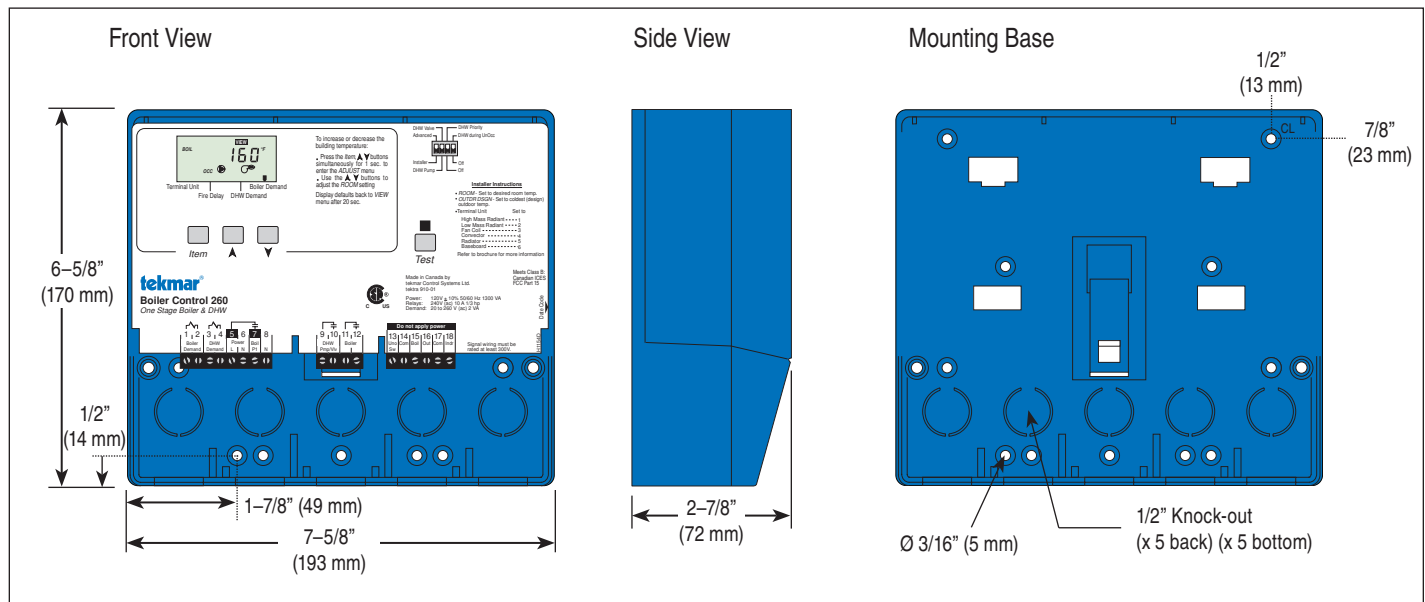

Specifications

Boiler Control 260 One Stage Boiler & DHW	
Literature	D260, A260, D001, D070
Control	Microprocessor control. This is not a safety (limit) control
Packaged weight	3.0 lb. (1340 g)
Dimensions	6-5/8" H x 7-9/16" W x 2-13/16" D (170 x 193 x 72 mm)
Enclosure	Blue PVC plastic, NEMA type 1
Approvals	CSA C US, meets class B: ICES & FCC Part 15
Ambient conditions	Indoor use only, 32 to 113°F (0 to 45°C), RH ≤90% Non-condensing
Power supply	120 V (ac) ±10%, 50/60 Hz, 1300 VA
Relays	240 V (ac) 10 A, 1/3 hp
Demands	20 to 260 V (ac) 2 VA
Sensors	NTC thermistor, 10 kΩ @ 77°F (25°C ±0.2°C) β=3892
-Included	Outdoor Sensor 070 and Universal Sensor 082
-Optional	tekmar type #: 033, 076, 077, 084
Warranty	Limited 3 Year (See D260 for full warranty)

Energy Saving Features

- Outdoor Temperature Reset
- Indoor Temperature Feedback (optional)
- Setback input for energy savings
- Warm Weather Shut Down
- Automatic Boiler Differential

Additional Features

- Quick setup for easy installation and programming of control
- User comfort adjustment to increase or decrease building space temperature
- Advanced settings to fine-tune building requirements
- Pump and valve exercising
- Powered boiler pump output
- DHW pump or valve operation
- Optional DHW priority
- Test sequence to ensure proper component operation
- 120 V (ac) power supply

SPECIAL REQUIREMENTS

N / A

