

Submittal Data Information

Roth DWT 400L



Effective: September 2007

Supersedes:

Job: _____ Engineer: _____ Contractor: _____ Rep: _____

ITEM PART NO.	ITEM DESCRIPTION	MANUFACTURER
#2335109001	110 Gal. (400 Liter) Double Wall Lube Storage Tank	Roth



The Roth Double Wall Lubricant Storage Tank (DWT) is made with a seamless blow-molded polyethylene inner tank and a 19 ga. galvanized outer tank. The outer tank is formed by joining cold rolled sheet steel, used to form the sides and bottom from a single piece, with two stamped metal end pieces. The edges between the sides and ends have sealant applied to them and are then rolled to create leak-proof seams. A stamped top is then pressed and riveted into place to complete the assembly of the DWT. The DWT is listed in the United States and Canada under ANSI/CAN/UL/ULC 2258 and approved under NFPA 31 and compliant with NFPA 30/30A as non-metallic combustible liquid storage tanks.

Both inner and outer tanks are pressure tested at the factory during assembly according to UL[®] standards and do not require further field testing. The DWT also

comes with a detached saddle base which the tank is placed on at the time of installation.

The tank shall be placed into service in accordance with local codes and the listed use (indoor or outdoor) on a flat, level and stable surface, away from heat sources, corrosive atmospheres or fluids, potential mechanical damage or rapid temperature changes. The final location must have the tank label visible after installation. A minimum of 2" (50 mm) from all walls or obstructions is recommended for normal tank expansion and visual inspection. The integral base support shall not be removed and raising the tank height is not allowed except on a continuous concrete platform at least 6" (150 mm) wider than the tank base at all sides. All local fire code set-backs for combustible liquid storage tanks must be observed.

Tanks installed indoors shall not be exposed to direct sunlight on any plastic parts. Tanks installed outdoors shall be assembled with the required cover, Roth #2335100749 for the 400L. All tanks must be installed with an atmospheric vent to provide pressure and vacuum relief during filling and operation.

Tank Model	DWT 400L
Nom. Capacity US gal (liters)	110 (400)
Length inches (cm)	29 (110)
Width inches (cm)	28 (72)
Height Inches (cm)	44 (112)
Min Height Req'd inches (cm)	49 (125)
Tank Weight lbs. (kg)	106 (48)
Shipping Weight lbs. (kg)	115 (52)

ROTH Industries, Inc, PO Box 245 Syracuse, NY 13211

Visit our website at: www.roth-america.com

Telephone: (315) 755-1011 Fax: (315) 755-1013
 Telephone: (800) 969-7684 Fax: (450) 464-7950

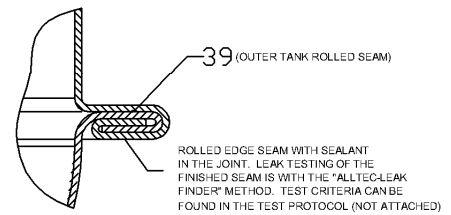
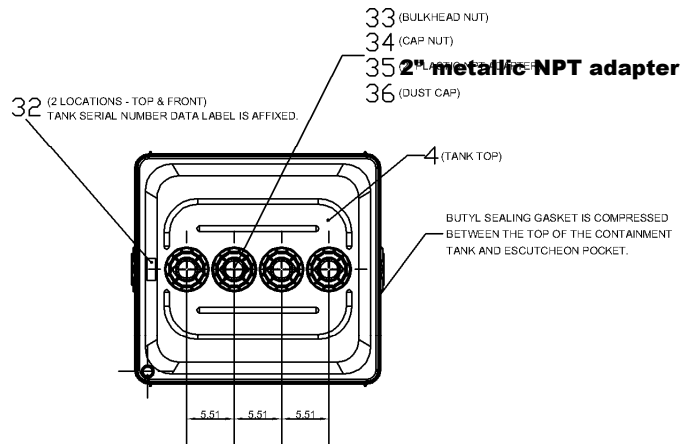
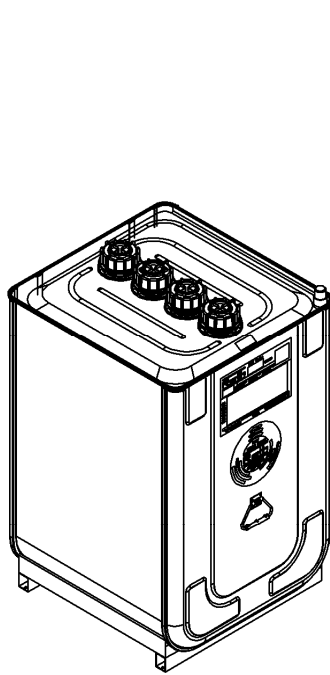
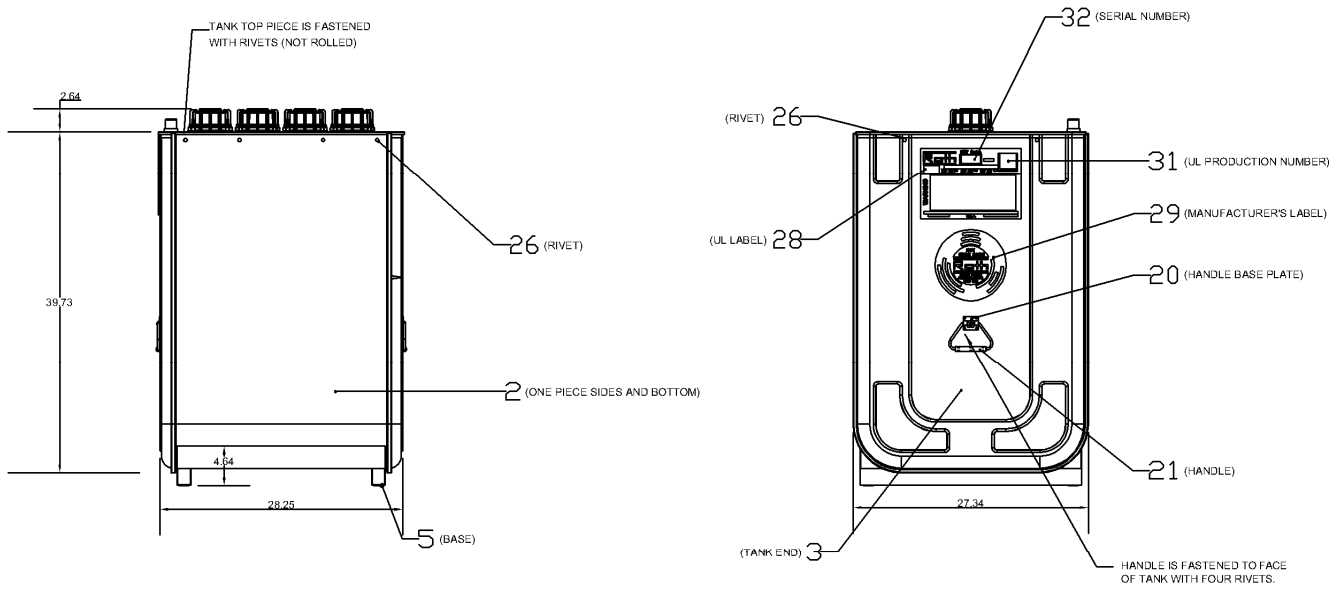

ROTH Industries, Inc, PO Box 245 Syracuse, NY 13211

Visit our website at: www.roth-america.com

Telephone: (315) 755-1011 Fax: (315) 755-1013
 Telephone: (800) 969-7684 Fax: (450) 464-7950