

# Roth CM Manifold System Installation Instructions

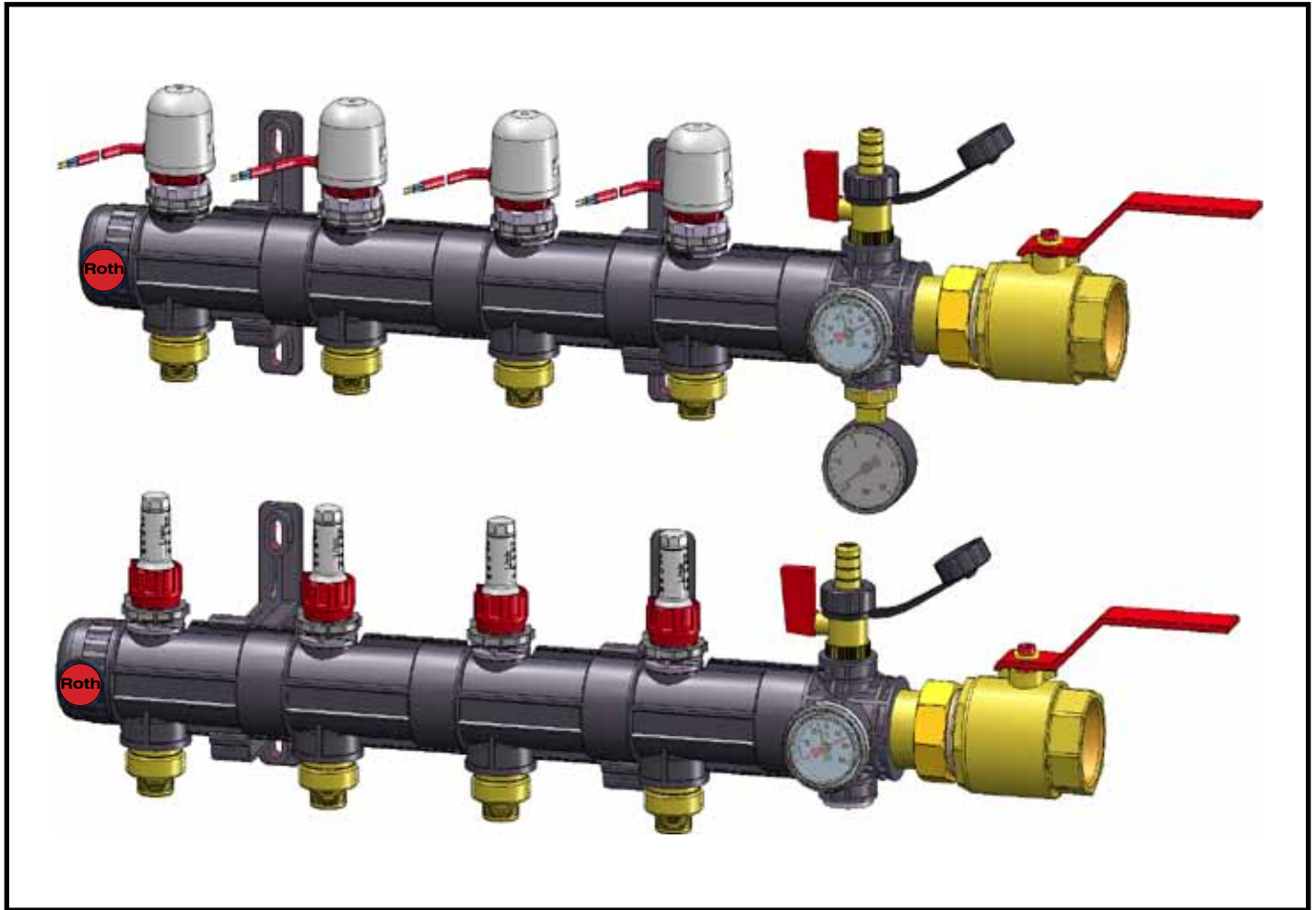

Roth Industries, Inc.  
268 Bellew Avenue South  
Watertown, NY 13601  
Ph. 315-755-1011  
Fax 315-475-0200

[www.roth-usa.com](http://www.roth-usa.com)  
[info@roth-usa.com](mailto:info@roth-usa.com)

# Roth CM Manifold System Installation Instructions



## Product Description

The Roth CM Manifold System is comprised of modular large bore manifolds constructed from glass-fibre reinforced polyamide.

Each manifold system includes:

- Supply and return ball valves - 1 1/2" FPT
- Manifold basic kit including:
  - Manifold cross pieces
  - Temperature gauges
  - Drain/fill valves
  - Mounting brackets
- Supply manifold segments (1-6) with adjustable flowmeters
- Return manifold segments (1-6) with manual valves and operators
  - Larger manifolds are created by combining smaller segments
- Expansion mounting kits (where needed)
  - See chart on page 4
- Automatic air vents
- Pressure Gauge (Optional)

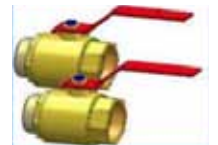

## Unpacking

Manifold system components come packaged in individual boxes and are placed in a master package.

Please inspect package and contents for damage during shipping.

# Roth CM Manifold System Installation Instructions



## Dimensions

# - Number of loops  
A - Length of segments

#	A	
	in	mm
2	10.0	250
3	12.5	320
4	15.5	390
5	18.1	460
6	21.0	530
7	23.5	600
8	26.5	670
9	29.1	740
10	32.0	810
11	34.5	880
12	37.5	950
13	40.2	1020
14	43.0	1090
15	45.5	1160
16	48.5	1230
17	51.2	1300
18	54.0	1370
19	56.7	1440
20	59.5	1510

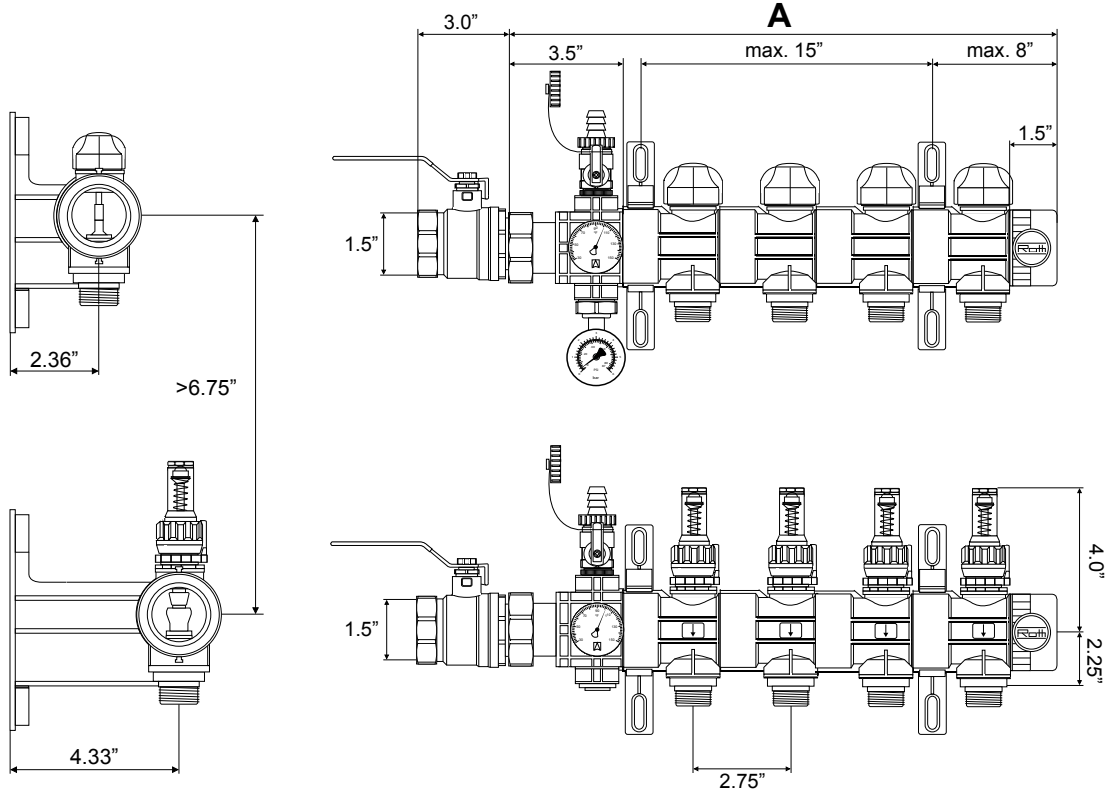

## Specifications

Parameter	Value
Operating Temperature and Pressure	Maximum 140°F @ 87 psi (60°C @ 6 bar) Maximum 194°F @ 43 psi (90°C @ 3 bar)
Maximum Operating Pressure	87 psi (6 bar)
Maximum Test Pressure	87 psi (6 bar) (24 hr, < 85°F (30°C))
Maximum Tightening Torque	59 ft lbs (80 Nm)
Maximum Heating Circuits	20 (20)
Thermometer Range	32°F - 140°F (0°C - 60°C)
Flowmeter Range	1 - 5 gpm (4 - 20 lpm)

# Roth CM Manifold System Installation Instructions



## Mounting

### Location guidelines

1. The manifold system must be accessible for future inspection and maintenance.
2. The supply/return and loop tubing should have an unobstructed approach and any bend radius must be large enough to prevent kinks.
3. Manifold system locations should not be in flood prone areas or exposed to the elements.
4. Avoid exposing tubing to direct sunlight, even through a door or window. Long term exposure to UV rays will cause the tubing to degrade.
5. If manifold systems are located in an unconditioned space, appropriate measures must be taken to prevent damage from freezing.
6. Manifolds must be level/plumb depending on mounting orientation.

### Mounting the Brackets

#### Number of required brackets

Heating loops	2-5	6-9	10-14	15-19	20
Required brackets	2	3	4	5	6

#### Distance between brackets

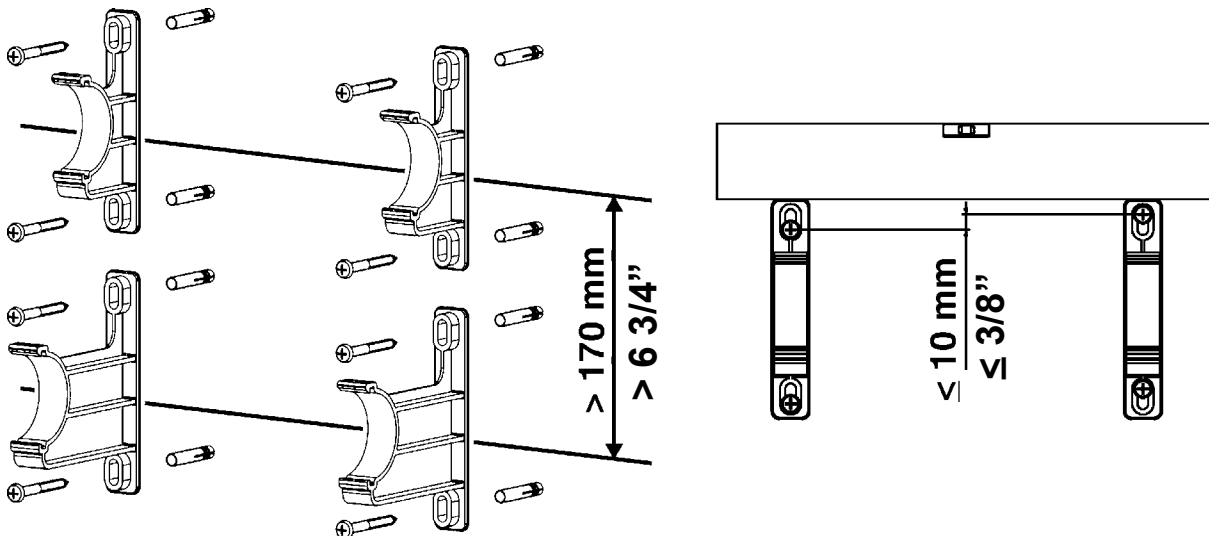

# Roth CM Manifold System Installation Instructions



## Mounting the manifold

Insert bottom ridge of manifold into bracket slots and twist into bracket until top ridge snaps into brackets.

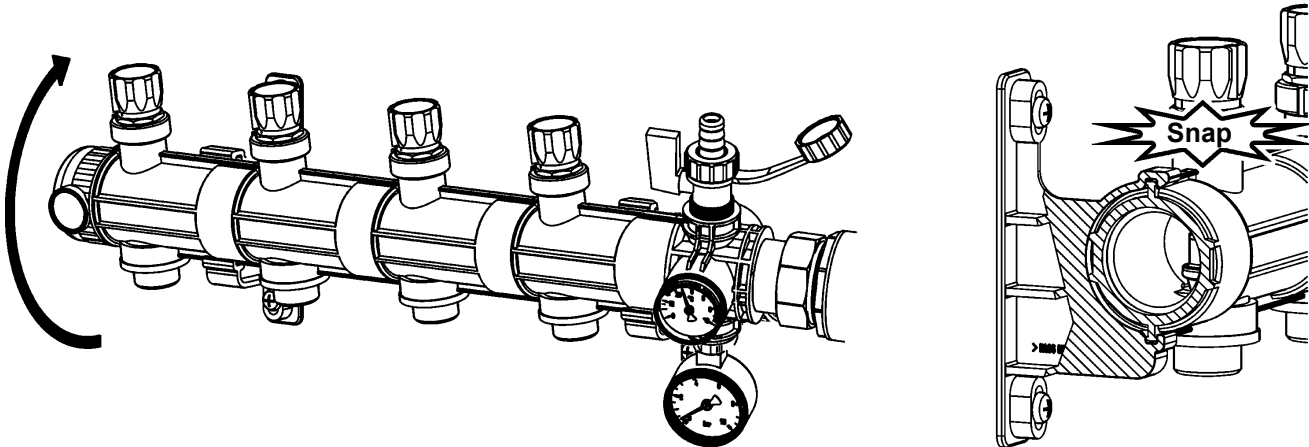

## Orientation

The CM manifold can be mounted in any position, however the following conditions may occur when manifolds are mounted in positions other than upright (loop tubing approaching from bottom):

1. Upside down position (loop tubing approaching from above)
  - a. Dirt may accumulate in the flow indicators over time. This will not have any effect on the flow rate but may cause flow indicators to give false readings or stop working altogether.
  - b. The flow indicators will indicate flow, however they will lose some of their precision in this orientation. The flowmeter will indicate 20% less than actual flow.
  - c. Air vents must be inverted to operate as intended.
2. Vertical position (loop tubing approaching from either side)
  - a. Dirt may accumulate in the flow indicators with the same effects as above.
  - b. The automatic air vent will not operate.

Caution: Conditions above do not qualify for warranty replacement.

## Hardware

There are four mounting holes in the bracket set that will accommodate a 1/4" (6mm) diameter fastener appropriate for the mounting surface material. These can include wood screws, sheet metal screws or through-bolting as required.

# Roth CM Manifold System Installation Instructions



## Pipe Connections

Supply and return connections

The pipe connections on the attached ball valves are 1 1/2" FPT. Use of a thread sealant compatible with water service is recommended.

## Loop Connections

Loop connections are standard threaded R-30 Euroconical compression fitting assemblies.

Roth Product #	Description
<b>PEX/PE-RT Fittings</b>	
2335001410	Manifold Tubing Fitting Assembly - 3/8" pkg of 10
2350003021	Manifold Tubing Fitting Assembly - 1/2" pkg of 10
2350003022	Manifold Tubing Fitting Assembly - 5/8" pkg of 10
2335001034	Manifold Tubing Fitting Assembly - 3/4" pkg of 2
<b>Alu-Laser Plus Fittings</b>	
2347131300	Manifold Tubing Fitting Assembly - 3/8" pkg of 10
2347002331	Manifold Tubing Fitting Assembly - 1/2" pkg of 10
2347002332	Manifold Tubing Fitting Assembly - 5/8" pkg of 10

Care should be taken to ensure that the tubing ends are cut square, and that there is no debris in the end of the tubing that may affect the integrity of the fitting.

Loop tubing approach to the manifold should be carefully managed to allow for minimum bend radius requirements and bend supports should be used if there are concerns for tubing kinking during manifold and floor installation and finishing.

**Caution:** Alu-Laser Plus tubing must be reamed with Roth Alu-Laser Plus reaming tool. This puts a bevel on the inside of the pipe and allows the fitting to be inserted into the pipe without disturbing the o-rings on the fitting. Failure to do so will cause leaks.

## Attaching Tubing to Manifold

- Place compression nut onto tubing with thread opening facing tubing end
- Fit split ring over tubing and move away from end at least 2" (50mm)
- Insert fitting into tubing until all barbs are covered
- Insert euroconical end of fitting into manifold until o-ring is seated
- Push split ring up against fitting
- Thread and tighten nut onto manifold

# Roth CM Manifold System Installation Instructions



## Attaching 3/4" tubing to manifold

- Insert euroconical end of fitting (1) into manifold until o-ring is seated
- Thread and tighten threaded adaptor (2) onto manifold
- Place compression nut (4) onto tubing
- Fit split ring (3) over tubing and move away from end at least 2" (50mm)
- Push tubing onto barbed fitting as far as possible. Be sure all barbs are covered
- Push split ring to within 1/8" from end of tubing
- Thread and tighten nut onto adaptor

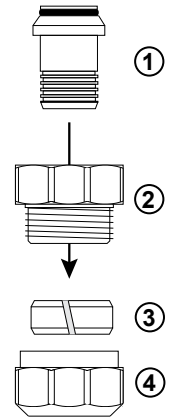

## Filling and purging

The direction of flow for filling and purging should always be from the supply manifold, through the loops, to the return manifold.

### Filling

- Close supply and return isolation ball valves
- Close the air vents
- Attach service hoses to barbed fittings on supply and return manifold fill/drain valves and secure with hose clamps. Open fill/drain valves
- Open all loop supply and return main valves
- Open water source and begin filling manifolds and loops. When a full stream of water exits the return hose open the manual air vents until water seeps out and close
- Shut off the water source and close fill/drain valves

### Purging

Note: Purging is most effective when each loop is purged individually. Domestic water pressure or a jet pump may be necessary to purge trapped air from the system.

- Attach service hoses to barbed fittings on supply and return manifold fill/drain valves and secure with hose clamps. Place return service hose in bucket to observe when air bubbles no longer exit the system, indicating it is purged. Open fill/drain valves.
- Open the return valve of the first heating loop (1)
- Open the supply valve of the first heating loop (3)
- Close all remaining supply and return valves (2)

# Roth CM Manifold System Installation Instructions

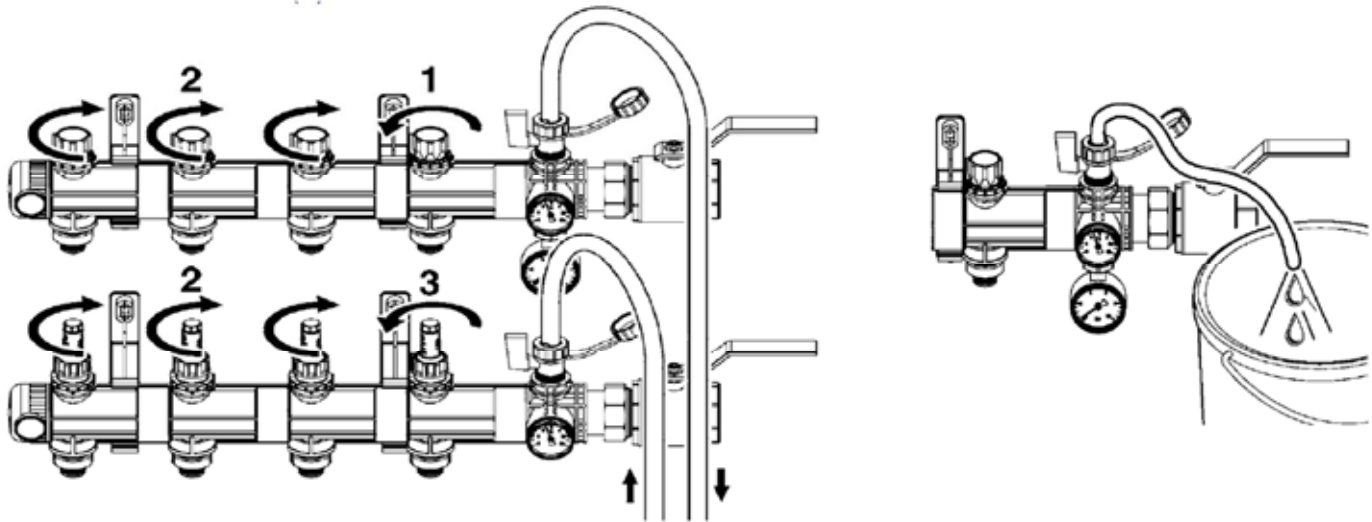

- Purge first loop with 40 - 70 psi to remove trapped air in loop
- Allow water to circulate until no air is discharged into the bucket
- Close supply and return valves on the first loop
- Repeat procedure until all loops have been purged
- Open the air vents until water seeps out and close
- Shut off the water source, close fill/drain valves and remove service hoses

## Pressure Testing

### Air test

- Pressurize system to 87 psi (6 bar) for a minimum of 2 hours
- Pressure drop allowance after this test is a maximum of 3 psi (0.2 bar)
- If pressure drop is greater, use leak detection fluid or ultrasonic leak detector to determine source of leak

### Fluid test

- Pressurize system to 87 psi (6 bar) for a minimum of 24 hours
- If pressure drop occurs, check for leaks
- Use caution when pressure testing with water in colder climates where freezing could occur



# Roth CM Manifold System Installation Instructions



## Loop flow adjustment

- The flowmeter is shipped in the fully closed position
- To open the flow valve and set the loop flow rate pull the stop ring (1) up and turn flowmeter (2) counterclockwise
- Once the flow rate is set, turn stop ring clockwise until the stop engages the stop on the flowmeter
- Push the stop ring down to lock

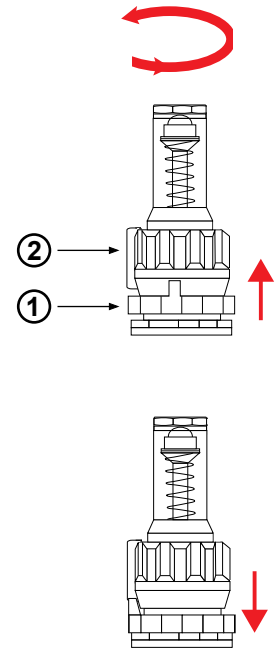

CM Manifold Pressure Drop Graph

